



MSA
DAMPER

COMPANY PROFILE



History

MSA DAMPER SRL was founded in 2019 by a Group of Industrial Investors which acquired the 25 years know-how and technology of Mediterr Shock Absorbers S.p.A.

The headquarters have been maintained in Asti in a complete high tech, new and functional plant, to which many of the latest-generation production systems were added and technologies always aiming to meet our market and customer's targets.



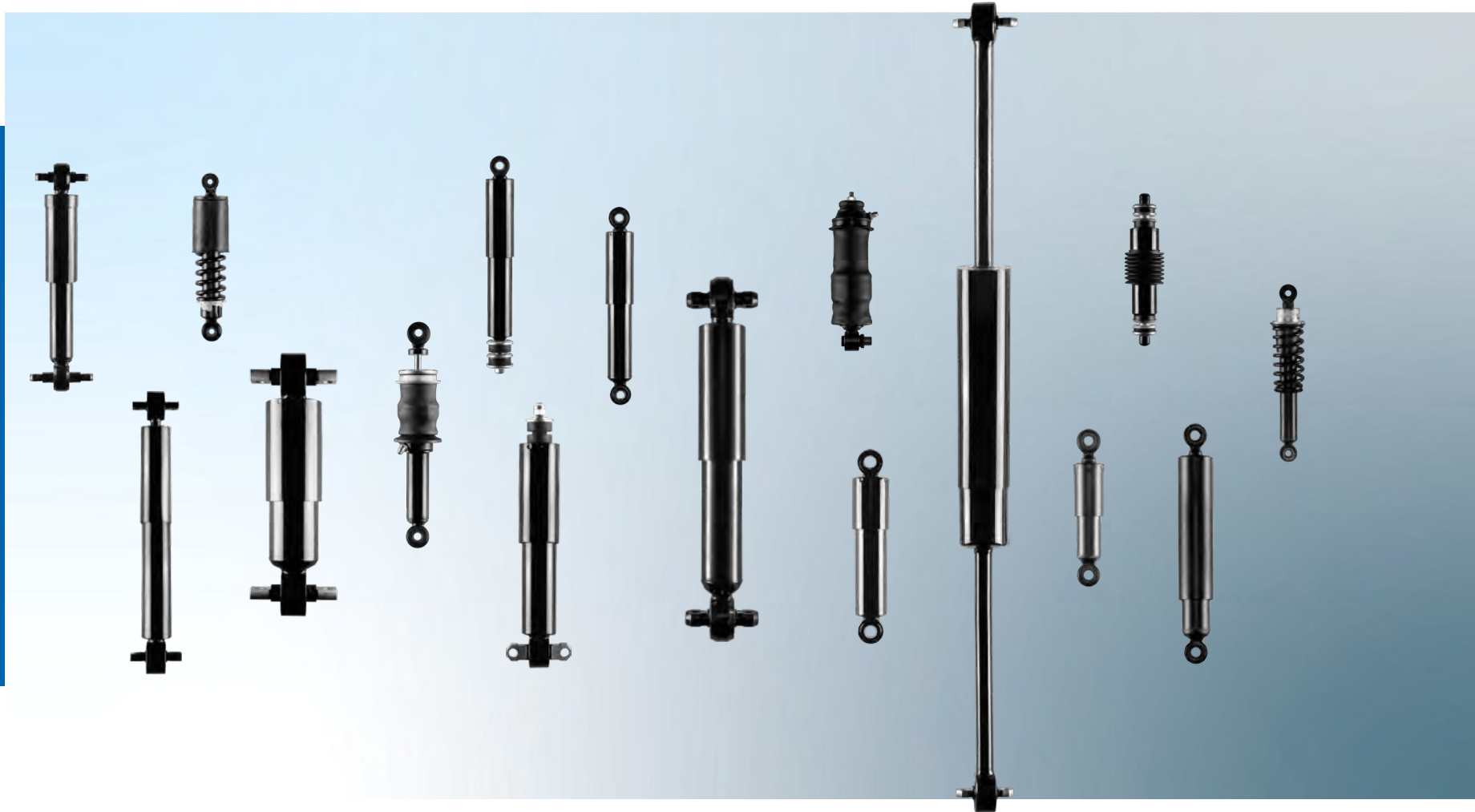

Bushings and rubbers for railway and automotive sectors

Elastic elements, torsion bar, connecting arm end bushing:

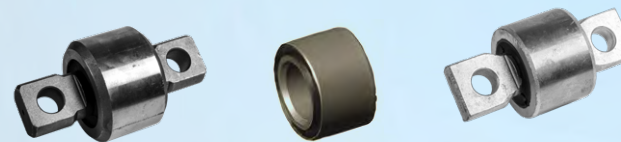

Screened support spring secondary suspension:



Gorto springs for secondary suspension:



Rubber rebound bumper:



Anti-vibration-damping floor:

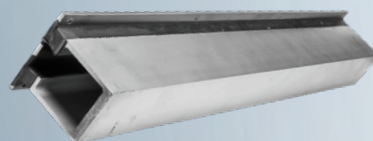

Conical springs primary suspension:



Gaskets, guards and technical articles on specific request:



The molding department is perfectly integrated into our production process and include injection and compression technologies (from 60 to 400 tons). The product range is comprehensive of anti-vibration mounts, end-of-stroke pads, silent blocks.



METRO

TRAM

HIGH SPEED

LOCOMOTIVE

TAF

Railway dampers

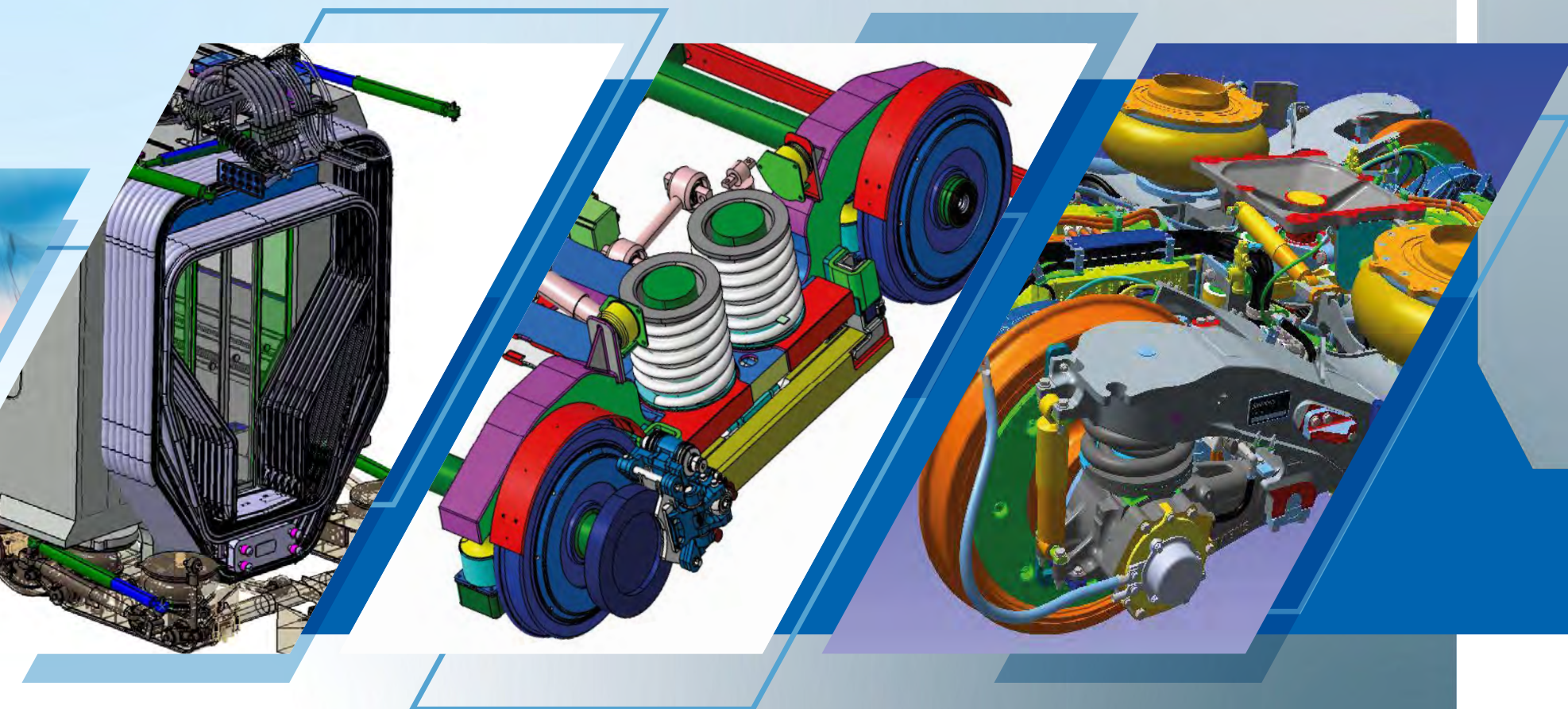

PRIMARY VERTICAL SUSPENSION - SECONDARY VERTICAL SUSPENSION - HORIZONTAL - YAW - INTER CARS

We always aim to meet the highest standards required by the railway industry by designing solutions which guarantee to set the technology we have for performances, reliability and always ensuring safety purposes

Commercial and special purpose vehicles

COMMERCIAL VEHICLES



TRUCK



CABIN SHOCKS



TRAILER & AXLES



BUSES



SEATS SHOCKS



Product customization

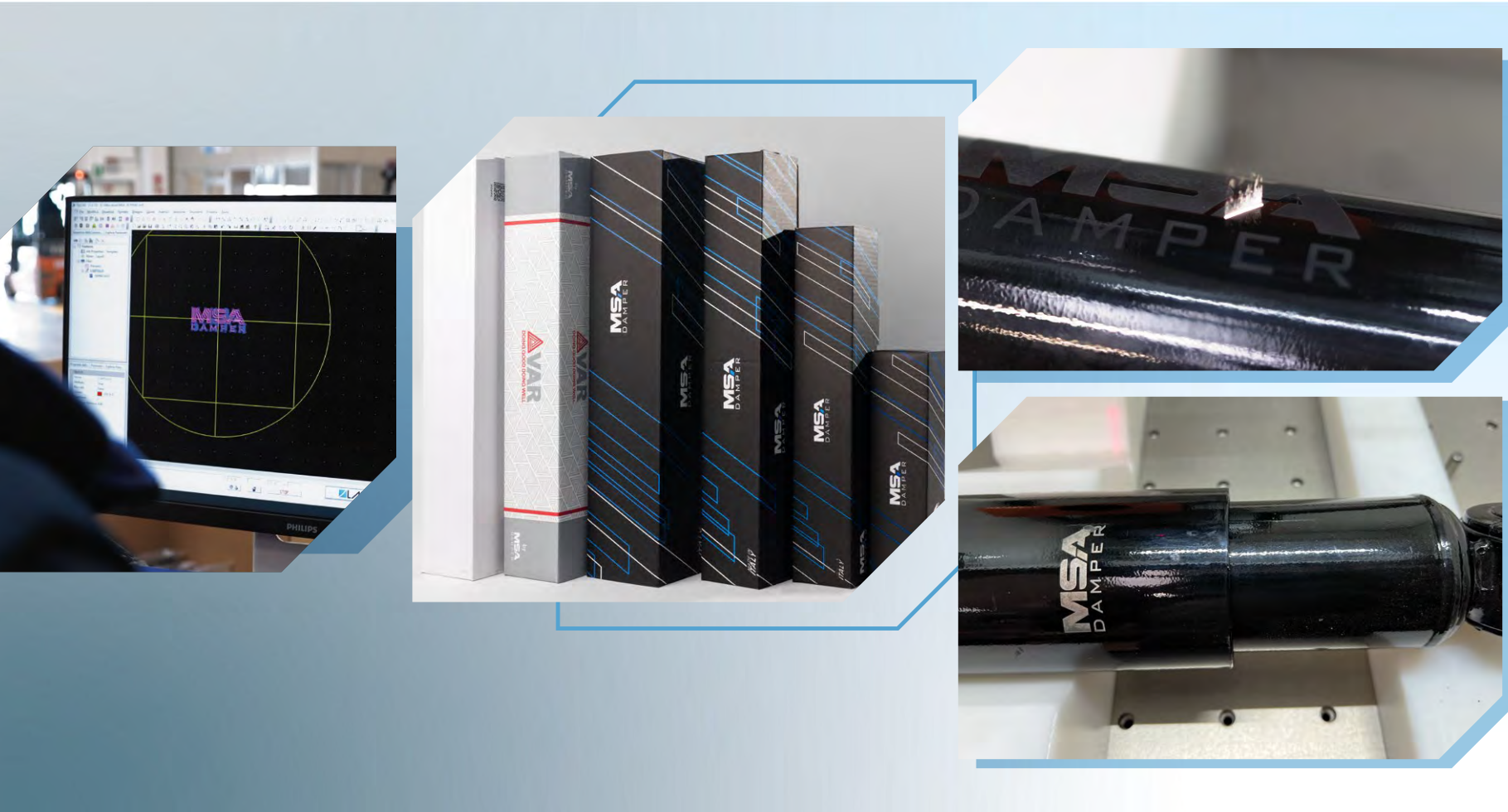

We can customise our products with Laser marking, and offer the best technology to ensure the readability and permanence of codes/names/brands. The laser can mark as small as 0.5 x 0.5 mm, and can customize the shock absorbers according to the customer's requests.



Testing



We always aim to guarantee our partners the delivery of reliable products with the best performances and optimized service intervals which are validated through our testing laboratory which can perform extreme life tests simulations.

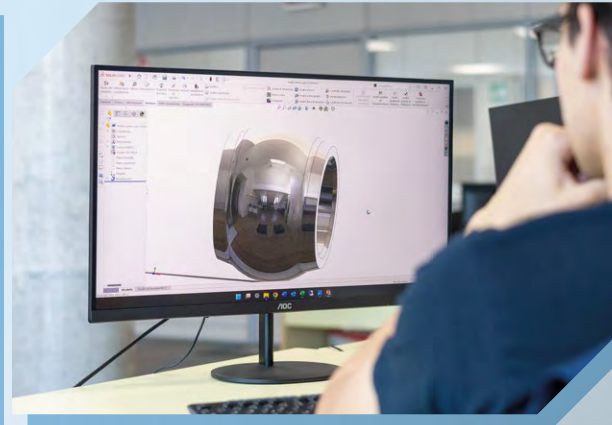
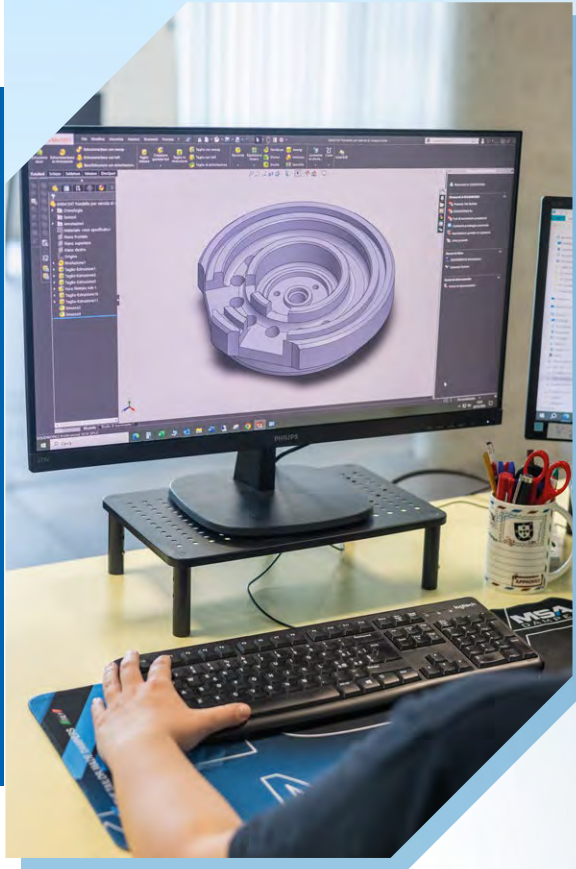

Technical department

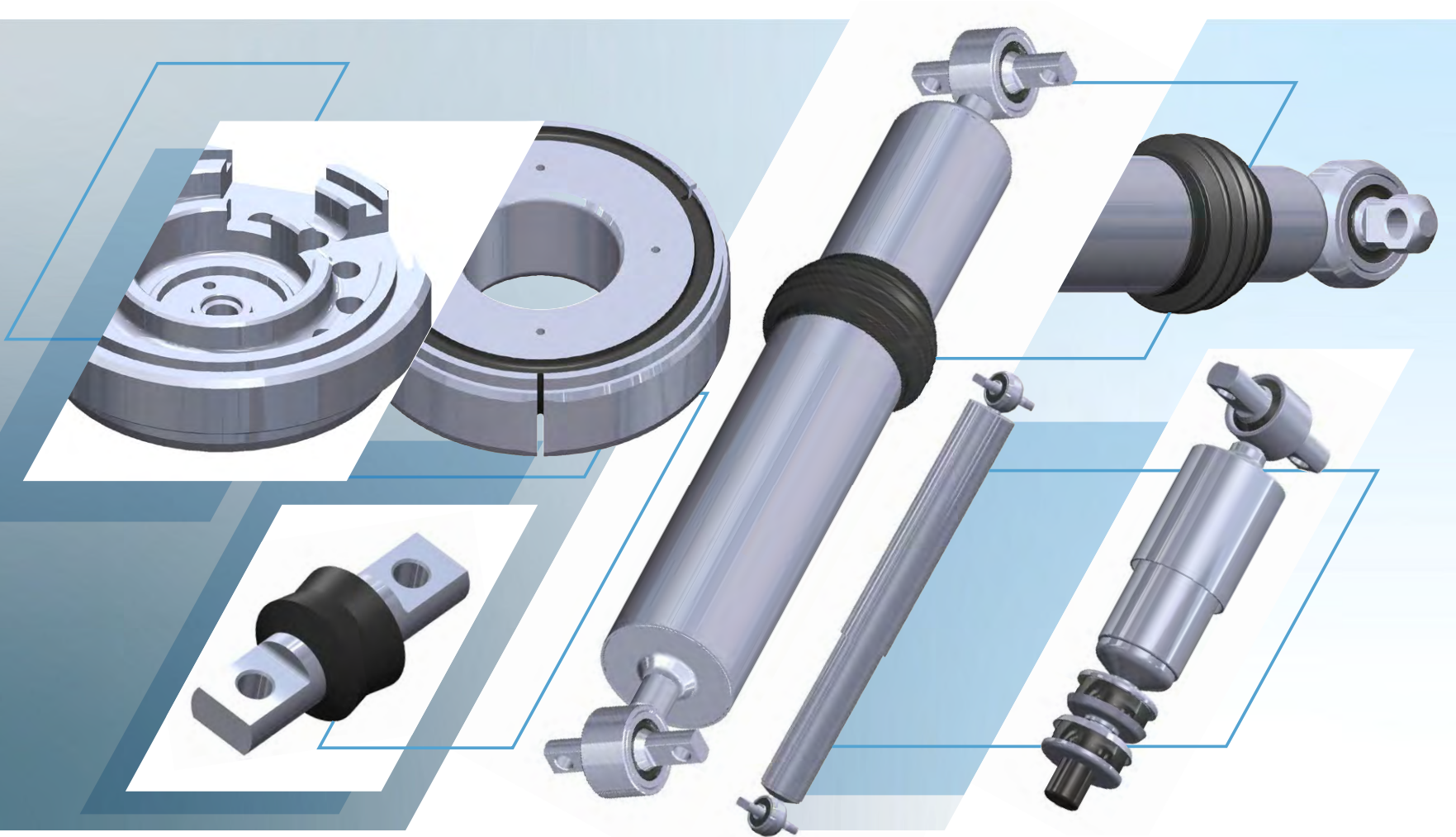

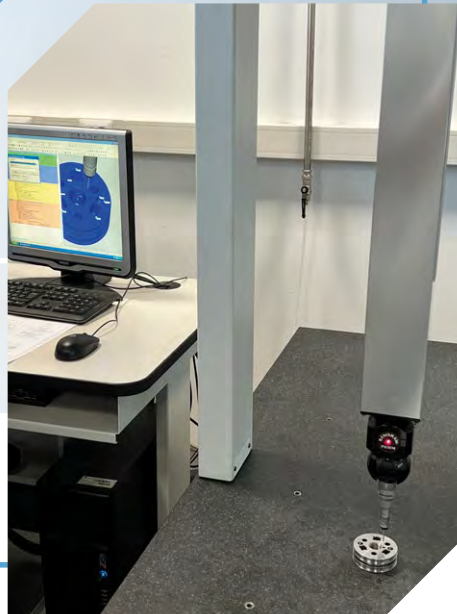

Certifications & Awards



MSA DAMPER has obtained the international certifications:

- ISO 9001:2015 quality management system
- ISO/TS 22163:2017 (IRIS rev O3) Railway applications - Quality management system
- EN 3834-2:2021 quality requirements for fusion welding of metallic materials
- EN 15085-2:2020 Railway applications - Welding of railway vehicles and components
- ISO 14001:2015 Environmental management system
- ISO 45001:2018 Occupational health and safety management system

MSA damper commitment to the future

ISO 14001
CO2 eq analysis
Damper
Overhaul

ENVIRONMENT

SUSTAINABLE

ECONOMIC

GOVERNANCE
ISO 9001
ISO 22163 (IRIS)

SOCIAL

ISO 45001
Gender
equality

Our mission is to commit to create an innovative and sustainable approach for a better future focused on a business's environmental, social and governance (ESG) profile.

Contribution to circular economy (CE) - 85% recyclable

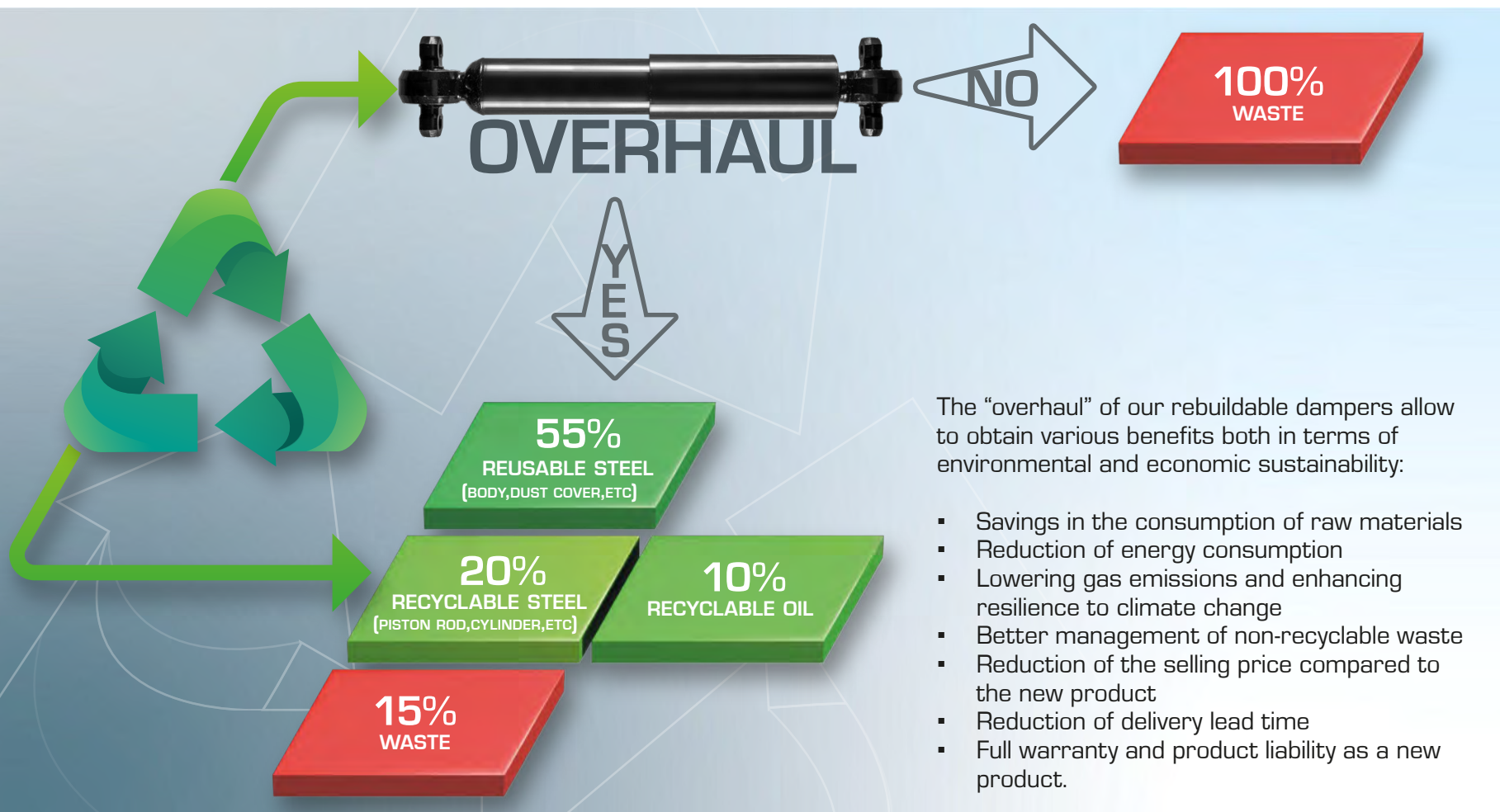

*Percentages calculated from average weights of yaw dampers.

CE is a system that aims to eliminate waste and minimize the use of finite resources.
By applying the core principles of CE we support the United Nations Sustainable Development Goals.

After market distribution network

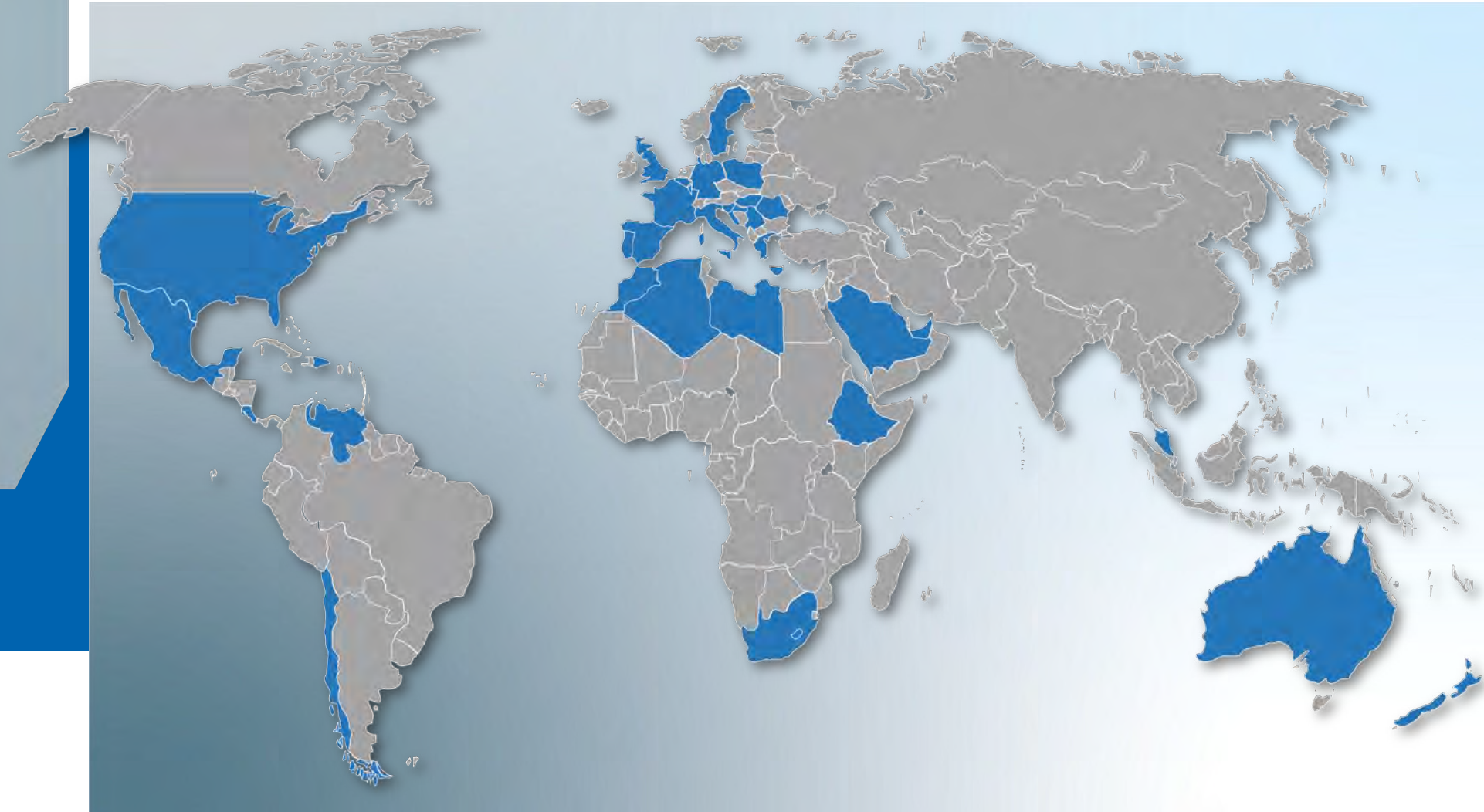

Main partners and associations



I V E C O • G R O U P

HEULIEZ | IVECO BUS | IVECO | IVECO DEFENCE VEHICLES | ASTRA | MAGIRUS





MSA Damper S.R.L.

Sede Generale - Headquarters
14100 Asti (AT) Via Learco Guerra 18

Magazzino - Warehouse
14100 Asti (AT) Via A. Griffa

P.Iva - C. fisc. 11010890967

tel +39 0141 178 5176

web msadamper.com

mail info@msadamper.com

pec msadampersrl@legalmail.it